



Valvole brevettate per compressori rotativi a vite e a pistoni
 Patented valves for piston and screw rotary compressors

**REGOLATORE ASPIRAZIONE ELETTRICO
 MOD. RB115E**

per elettrocompressori a vite con funzionamento on-off

**ELECTRIC INTAKE REGULATOR VALVE
 MOD. RB115E**

for electrical screw compressors with on-off working

KIT RICAMBI RB115E - SPARE PART KIT RB115E		
Tempo Manutenzione / Maintenance Time : 8.000 ore/hours		
COMPLETO COMPLETE 620.0560	K1	KIT RICAMBI CILINDRO COMANDO SERVO CYLINDER SPARE PARTS KIT
	K2	KIT RICAMBI BLOCCHETTO COMANDO CONTROL UNIT BLOCK SPARE PARTS KIT

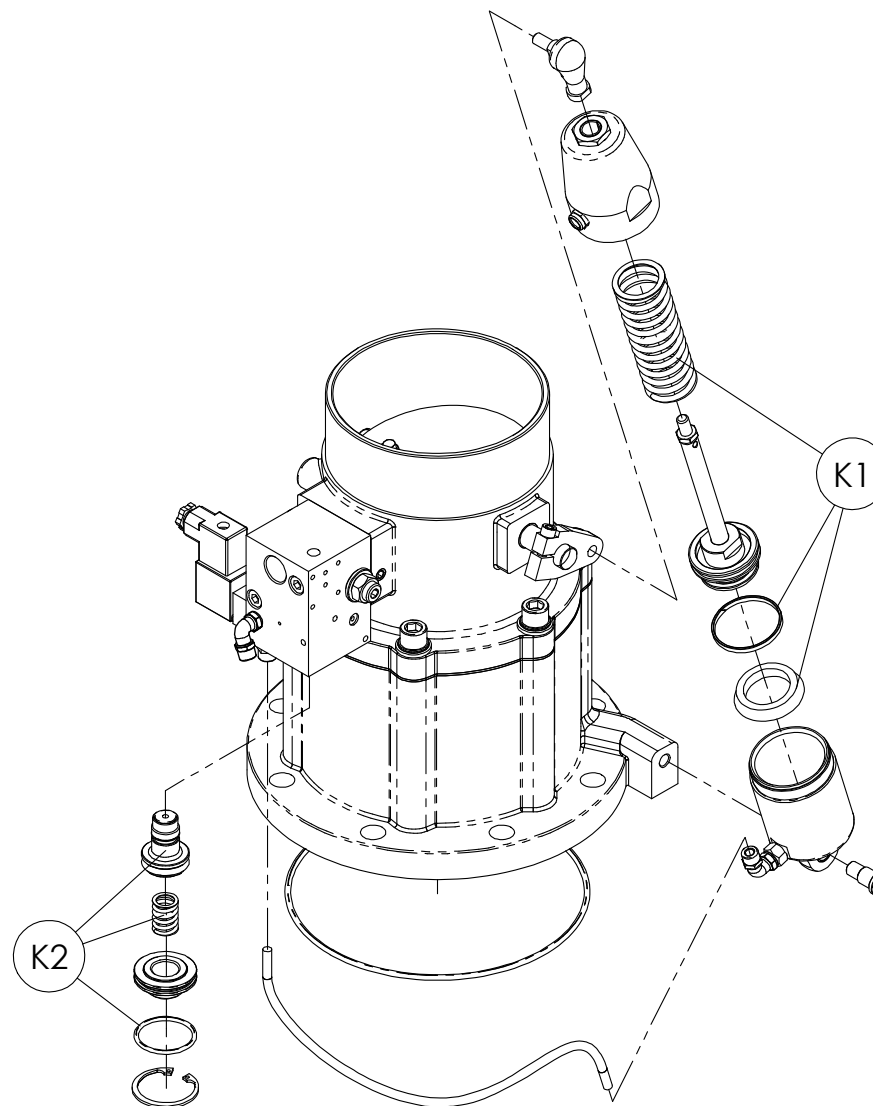

V.M.C. s.p.a. - Via A. Da Schio, 4/A-B - I-36051 CREAZZO (VI) - ITALY - Internet: www.vmcitaly.com
 Tel. +39 0444 / 521471 - 0444 / 341115 - Fax +39 0444 / 275112

TIPO TYPE	DM	REVISIONE REVISION	00	DATA DATE	07/06	GRUPPO LINE	620	ARTICOLO ARTICLE	.05	MODELLO MODEL	60
--------------	----	-----------------------	----	--------------	-------	----------------	-----	---------------------	-----	------------------	----



Valvole brevettate per compressori rotativi a vite e a pistoni
Patented valves for piston and screw rotary compressors

ANALISI DEI GUASTI

TROUBLE SHOOTING LIST

• **REGOLATORE ASPIRAZIONE MOD. RB90E – RB115E – RB140E – RB200E**

SINTOMO	PROBABILE CAUSA	AZIONE CORRETTIVA
Il compressore non carica o carica molto lentamente	<ol style="list-style-type: none"> 1. Tensione elettrovalvola errata 2. Elettrovalvola guasta 3. Guarnizioni pistoncino comando usurate 4. Guarnizioni cilindro comando usurate 5. Tubo collegamento da blocchetto comando a cilindro comando danneggiato 	<ol style="list-style-type: none"> 1. Controllare con test la tensione con cui viene alimentata l'elettrovalvola 2. Togliere elettrovalvola e sostituirla 3. Sostituzione KIT K2 4. Sostituzione KIT K1 5. Sostituzione tubo Rilsan
Il compressore continua a caricare oltre la pressione d'esercizio.	<ol style="list-style-type: none"> 1. Rottura molla cilindro comando 	<ol style="list-style-type: none"> 1. Sostituzione KIT K1
Il compressore una volta arrivato alla pressione d'esercizio chiude l'aspirazione ma scarica la pressione all'interno del disoleatore molto lentamente (La pressione all'interno del serbatoio d'utilizzo continua a scendere nonostante non ci sia consumo in linea e il compressore continua a caricare e scaricare aria)	<ol style="list-style-type: none"> 1. Valvola di minima pressione malfunzionante. 	<ol style="list-style-type: none"> 1. Vedi tabella guasti valvole di minima pressione
In fase di marcia a vuoto la minima pressione va a zero	<ol style="list-style-type: none"> 1. Registrazione by-pass aria e scarico non corretta (scarico troppo elevato rispetto ad iniezione) 	<ol style="list-style-type: none"> 1. Regolare vite registro by-pass aria J e scarico B, vedi documento completo
Fuoriuscita olio da bocca aspirazione alla fermata del compressore	<ol style="list-style-type: none"> 1. Livello dell'olio all'interno del disoleatore troppo elevato 2. Rottura molla non ritorno farfalla 3. Guarnizione farfalla non ritorno usurata 	<ol style="list-style-type: none"> 1. Controllare livello olio del disoleatore e se necessario togliere la quantità in eccesso 2. Sostituzione molla non ritorno farfalla * 3. Sostituzione farfalla non-ritorno* <p>* Vedi schema sottoriportato</p>
Presenza d'olio sul filtro aria in fase di marcia a vuoto	<ol style="list-style-type: none"> 1. Livello dell'olio all'interno del disoleatore troppo elevato 2. Filtro disoleatore saturo 	<ol style="list-style-type: none"> 1. Controllare livello olio del disoleatore e se necessario togliere la quantità in eccesso 2. Controllare l'integrità' del filtro aria-olio sul disoleatore e se necessario sostituirlo

V.M.C. s.p.a. - Via A. Da Schio, 4/A-B - I-36051 CREAZZO (VI) - ITALY - Internet: www.vmcitaly.com

Tel. +39 0444 / 521471 - 0444 / 341115 - Fax +39 0444 / 275112

TIPO TYPE	DM	REVISIONE REVISION	00	DATA DATE	07/06	GRUPPO LINE	620	ARTICOLO ARTICLE	.05	MODELLO MODEL	60
--------------	----	-----------------------	----	--------------	-------	----------------	-----	---------------------	-----	------------------	----



Valvole brevettate per compressori rotativi a vite e a piston
 Patented valves for piston and screw rotary compressors

INTAKE REGULATOR VALVE MOD. RB90E - RB115E - RB140E - RB200E

SYMPTOMS	PROBABLE CAUSE	CORRECTIVE ACTION
The compressors doesn't load or loads slowly.	1. Solenoid voltage wrong 2. Solenoid valves broken 3. Piston's gasket worn (inside the control block unit) 4. Servo cylinder's gasket worn 5. Rilsan pipe from control block unit to servo cylinder damaged	1. Controls the voltage which is power supplied 2. Remove the solenoid valve and replace it 3. Replace the piston by K2 spare part kit 4. Replace the gasket by K1 spare part kit 5. Replace Rilsan pipe
The compressor keeps on loading over the working pressure	1. Servo cylinder's spring broken	1. Replace the spare part kit K1
The compressor arrived at max pressure close the suctions but unload the air too much slowly.	1. Minimum pressure valve doesn't work correctly	1. See trouble shooting list of minimum pressure valve
During idling condition the minimum pressure goes to zero	1. Adjustment between air by-pass screw and venting time screw not correct (unload is much higher than injection)	1. To set air by-pass adjusting screw J and venting time adjusting screw B, see the assembly instructions.
Oil into the air filter junction after the compressor shut down	1. Oil level inside the tank separator too much high 2. No-return spring broken 3. No-return throttle gasket worn	1. Check oil level in the tank separator and eventually remove the exceeding oil 2. Replace the no-return spring* 3. Replace the no-return Throttle * * See below picture*
Oil into the air filter junction during idling condition	1. Oil level inside the tank separator too much high 2. Separator filter obstructed or damaged.	1. Control the oil level into the separator Tank. If it necessary remove the exceeding oil . 2. To check the separator filter is not damaged or dirty. If it necessary replace it.

V.M.C. s.p.a. - Via A. Da Schio, 4/A-B - I-36051 CREAZZO (VI) - ITALY - Internet: www.vmcitaly.com
 Tel. +39 0444 / 521471 - 0444 / 341115 - Fax +39 0444 / 275112

TIPO TYPE	DM	REVISIONE REVISION	00	DATA DATE	07/06	GRUPPO LINE	620	ARTICOLO ARTICLE	.05	MODELLO MODEL	60
--------------	----	-----------------------	----	--------------	-------	----------------	-----	---------------------	-----	------------------	----



Valvole brevettate per compressori rotativi a vite e a pistoni
Patented valves for piston and screw rotary compressors

SCHEMA POSIZIONAMENTO
FARFALLA N.R. MOD. RB115E

POSITION SCHEME
THROTTLE N.R. MOD. RB115E

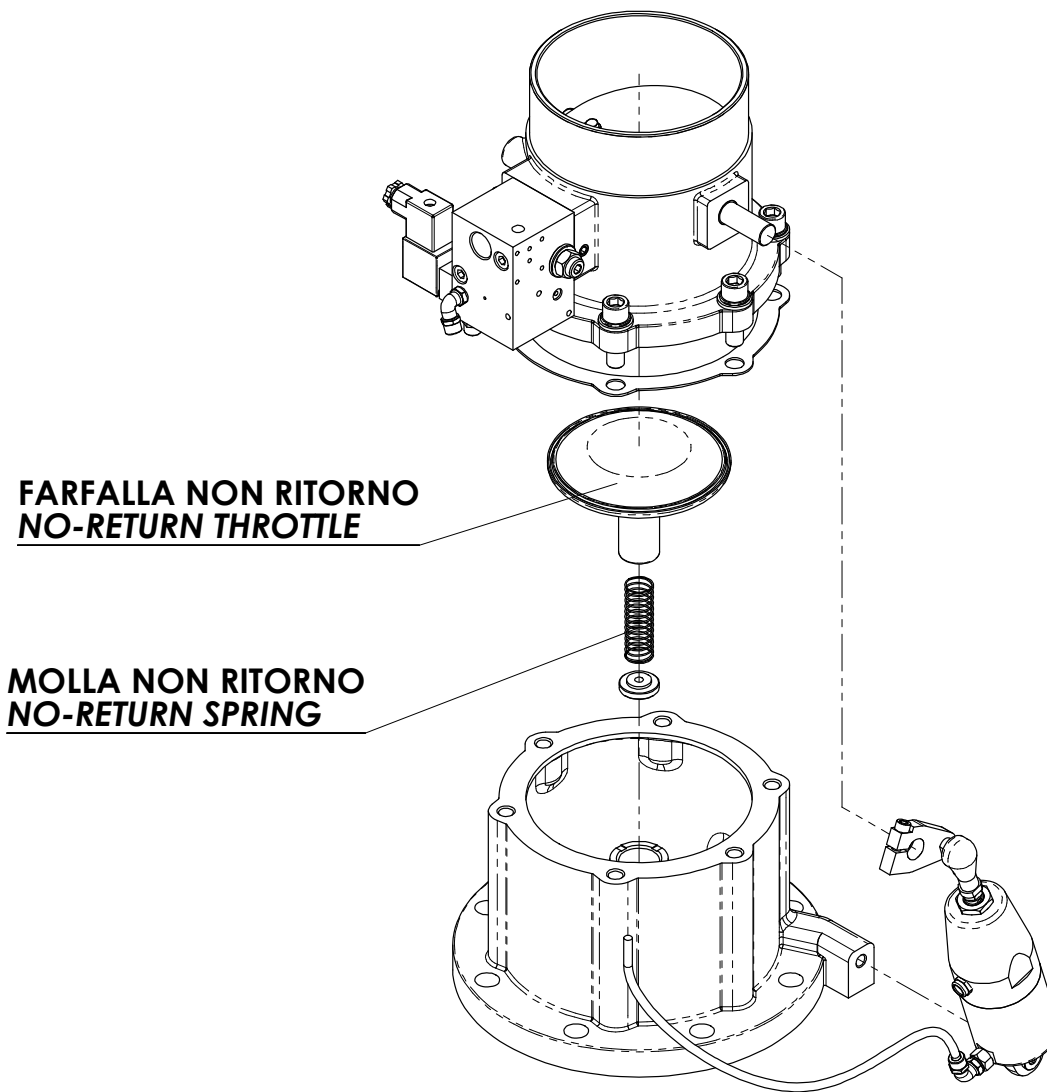

V.M.C. s.p.a. - Via A. Da Schio, 4/A-B - I-36051 CREAZZO (VI) - ITALY - Internet: www.vmcitaly.com
Tel. +39 0444 / 521471 - 0444 / 341115 - Fax +39 0444 / 275112

TIPO TYPE	DM	REVISIONE REVISION	00	DATA DATE	07/06	GRUPPO LINE	620	ARTICOLO ARTICLE	.05	MODELLO MODEL	60
--------------	----	-----------------------	----	--------------	-------	----------------	-----	---------------------	-----	------------------	----